

# Development of a CdZnTe-based Small Field of View Gamma Camera

K.B. Parnham, J. Grosholz, R. K. Davis, S. Vydrin, C. A. Cupec

eV PRODUCTS a division of II-VI Inc.,  
373 Saxonburg Blvd.,  
Saxonburg, PA 16056, USA

## ABSTRACT

The interest in the use of CdZnTe room-temperature, solid-state detectors for Nuclear Medicine applications continues to grow. Efforts are underway at several companies and institutes to develop CdZnTe detector systems to compete with existing scintillator-based Large Field of View (LFOV) gamma cameras. eV PRODUCTS is focusing on the development of Small Field of View (SFOV) gamma cameras using monolithic CdZnTe detector arrays coupled to custom designed, low noise analog read-out electronics. Electronic noise in the ASIC's has been minimized, and is typically less than 100 e<sup>-</sup> rms (0pF). The detector readout system has the capability to perform automatic energy calibration, gain setting and discriminator level setting, along with a comprehensive self-diagnostic routine. The complete integrated unit includes a bias voltage generator, counters and communication control. A first prototype 256-channel device has been developed and constructed, with pixel dimensions of 1.8 x 1.8 mm<sup>2</sup>, on a 34 x 34 x 5mm<sup>3</sup> monolithic CdZnTe detector. Results obtained from this system will be presented, showing both the energy resolution and uniformity data for several arrays. The energy resolution has been demonstrated to be 3-5% FWHM @ 140 keV, with photopeak efficiencies of 70-80%.

**Keywords:** CdZnTe, Small Field of View, gamma camera, ASIC, energy resolution, photopeak efficiency

## 1. INTRODUCTION

The use of CdZnTe in Nuclear Medicine continues to expand, and detectors based on this material are now commonly found in Bone Mineral Density (BMD) measuring systems<sup>1</sup>, intra-operative probes<sup>2</sup> and source calibrators prior to implantation during brachytherapy. However, the widespread deployment of imaging systems based on CdZnTe has not yet been seen, although many groups are working on these devices. Small field of view (SFOV) cameras have been demonstrated by Digirad<sup>3</sup>, Soreq<sup>4</sup> and LETI<sup>5</sup> but none have yet found their way into commercial application. Indeed, Digirad have abandoned the use of CdZnTe and changed to a CsI(Tl)/PIN diode system, mainly due to concerns about cost and availability. Large field of view (LFOV) systems have been conceptually shown by GE and Siemens, in collaboration with Imarad, and Marconi recently announced that they were working on a new concept for Nuclear Medical imaging, in collaboration with eV PRODUCTS. The advantages offered by the use of a room temperature operation direct conversion material such as CdZnTe are many, including superior energy resolution, better scatter rejection and a compact and rugged package, and these continue to be the driving force behind the efforts to develop gamma cameras based on CdZnTe<sup>6,7,8</sup>.

Recently, eV PRODUCTS was approached by a Japanese company, Anzai Medical Co. Ltd, to develop a hand-held, SFOV gamma camera, based on CdZnTe. The device was intended to be used intra-operatively, initially in sentinel node localization and identification in breast cancer patients. The program was later extended to include the development of a 64-channel, linear array, imager. The constraints imposed by the need to be hand-held required the development of an innovative approach to the problem, as the traditional method of data transmission (pixel address and pulse height for each event) proved to be impractical mainly due to space constraints and the requirement for the system to operate with a standard PC for image display and data storage. The solution adopted involved the pre-processing of all events in the imaging head and the data transmitted to the display processing system consists only of a string of numbers corresponding to the number of counts in the preset energy window for each individual pixel.

The final prototype imaging head uses a 34.1 x 34.1 x 5 mm<sup>3</sup> CdZnTe detector, with 1.8 x 1.8 mm<sup>2</sup> pixels arranged in a 16 x 16 matrix. The readout uses the custom ASIC preamplifier/shaper designed by Brookhaven National Laboratory and eV PRODUCTS that has been described elsewhere<sup>9</sup>. These ASIC's are 16-channel devices, and they are arranged in groups of 4

on a printed circuit board, each PCB also having 1 Field Programmable Gate Array (FPGA) comprising the counters and logic circuitry. Individual comparators are arranged for each pixel and a global trigger provides the necessary pixel address and start pulse. The device is controlled by a Motorola MPC555 micro-controller, which provides the auto-calibration and test protocols for the system. The output is currently via the standard RS232 interface to a PC, running at 115.2 kBaud. Performance tests to date demonstrate excellent energy resolution (typically 4-5% @ 122 keV) and good uniformity of response over the entire detector.

## 2. DESCRIPTION OF SYSTEM

The CdZnTe detector is a monolithic block, cut from within a single grain of the HPB-grown ingot but not necessarily free from growth twins. It is mechanically polished to achieve the required flatness and parallelism, followed by a chemical etch (Bromine/Methanol, 5%) to remove any damaged surface layers. The standard eV PRODUCTS sputtering technique is used to apply a contiguous Platinum contact to the cathode side and an array of 256 pixels (16 x 16 matrix) applied to the anode side, each pixel measuring 1.8 x 1.8 mm<sup>2</sup>, on a 2.0 mm pitch. The detector array is surrounded on the anode side by a traditional guard ring, separated from the pixel pattern by 0.5 mm, with a width of 0.5 mm. The detector is then mounted onto an alumina mounting substrate, having an array of bonding pads corresponding to the pixel array, using a patented process. This process entails the application, via screen printing, of an array of conductive polymer bumps which are cured overnight at ~ 80°C. The substrate then has another array of bumps printed on to its' pixels, the 2 sides are brought into contact and the device cured overnight, in a fixture to prevent movement. Prior to the bonding step, 4 connectors are soldered to the back of the mounting substrate, each having 64 pins, to allow for the mounting onto the ASIC readout. Finally, the connector for the bias is soldered to the mounting substrate and the top wire from the connector to the cathode is attached.

The ASIC boards carry the custom-designed 16 channel ASIC preamplifier/shaping amplifiers, arranged on both sides of the circuit board. The outputs from each ASIC are fed into a 16:1 multiplexer, which, having been triggered by a signal from a global trigger, sends the signal from the active pixel to a high- and low-level threshold. Any pulse that has an amplitude between these two levels will cause the counter associated with that pixel to increment by 1. The system is re-set by the trailing edge of the shaped pulse re-crossing the trigger threshold as it returns to baseline. The total time required by the system to process an event is defined by the peaking time of the amplifier plus the switching times for the discriminator, counters and multiplexer. This, for a standard peaking time of 1 microsecond, results in a dead time per event of ~3 microseconds. All thresholds (global, upper and lower) are controlled by the microcontroller, with the global threshold being common for all channels and the upper and lower being independently controllable for each channel. The micro controller also allows for the ASIC gain to be set to either a range of 15 – 300 keV or 15 – 600 keV (200 mV/fC max. or 100 mV/fC max.) Figure 1 shows a simplified block diagram of the system.

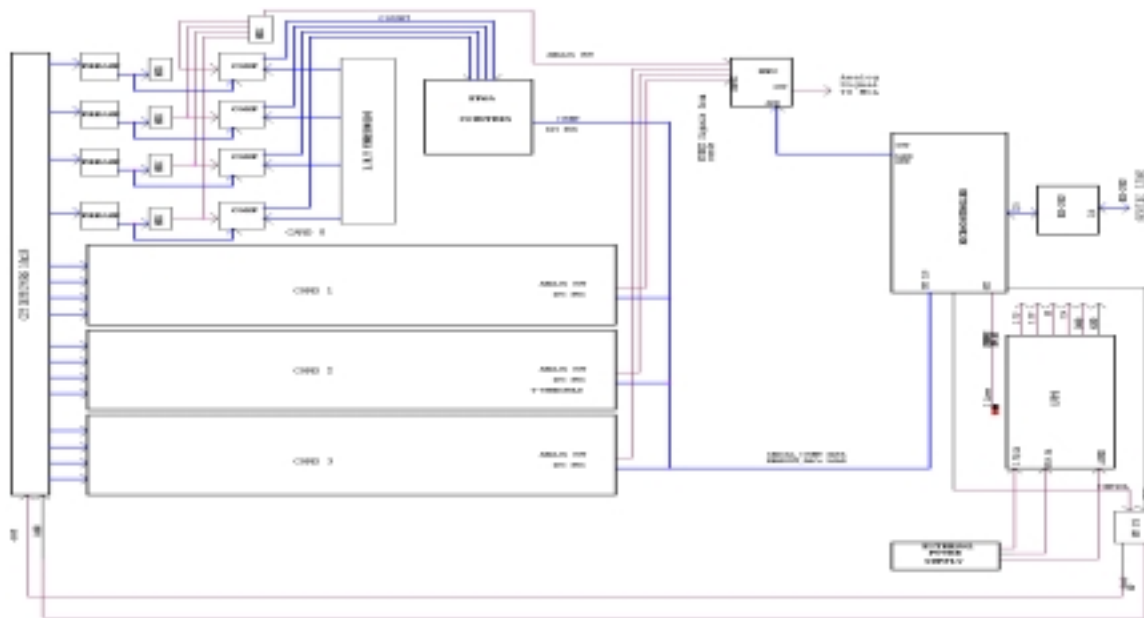

Figure 1: Simplified block diagram of the system

The motherboard, or micro controller board, carries all components for the control of the unit and all communication. The communications between the imager and the host computer are handled through the serial port, using RS-232 communication protocol at a transfer rate of 115.2 kBaud. Data is read from all of the counters after a user-selectable acquisition period that may vary from 150 ms to 10 s. The mother board also carries the HV supply, which uses a 5V input DC-DC converter, giving an output range of 300-600V, although this can be varied by using converters of different ratings. The 5V DC input is provided by a separate low voltage power supply and transferred to the imager via a multi conductor cable and a 19 pin Fischer connector.

### 3. PERFORMANCE

The performance of the system was tested initially in the laboratory by using standard radioactive sources. The normal source used to substitute for  $^{99m}\text{Tc}$ , which is the target isotope for this system, is  $^{57}\text{Co}$ , emitting at 122.1 keV in place of 140 keV. The initial tests were performed without the use of a collimator, in order to verify that the system was functioning. The unit has the ability to lock any one of the analog output channels and this signal can be sent directly to a Multi Channel Analyzer (MCA). The signal level is relatively small, typically having a full dynamic range of only 2 volts, therefore the MCA must be configured to accept the signal from an external amplifier and the ADC configured to convert only in the first  $\frac{1}{4}$  of the memory. Figure 2 is the spectrum from a randomly chosen pixel, demonstrating that, even though the analog signal is transferred on an unshielded track on the PCB's, it does not pick up excessive noise.

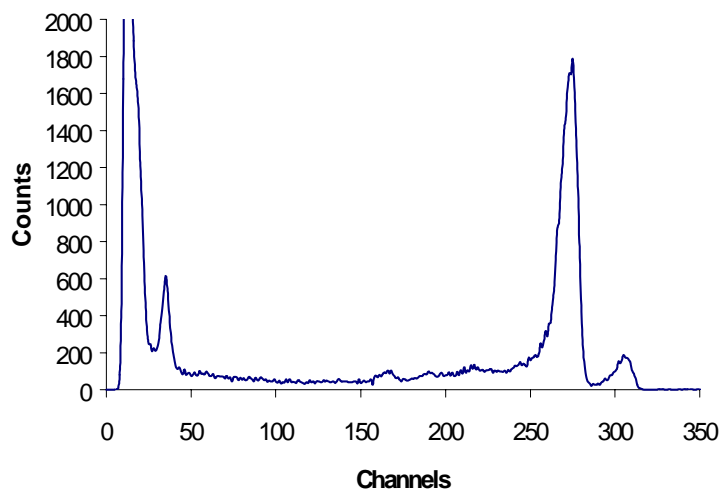

Figure 2: Response of a randomly chosen pixel to a  $^{57}\text{Co}$  source

As a function of the low noise levels in the detector, a test was performed to show the performance at low energy, especially at  $^{125}\text{I}$  energies. Figure 3 shows the response, demonstrating clearly that the 22 keV x-ray peak from a  $^{109}\text{Cd}$  source is fully resolved. Figure 4 shows the response of the same pixel to other sources commonly found in laboratories or industry. It should be noted that the spectra displayed in the latter figure were obtained with a lower gain than the first spectra. This level of performance is typical for the majority of pixels on the array tested, although there is a small number of pixels, especially close to the periphery of the device, that exhibit a poorer resolution. It is not clear at this time whether this represents a problem with the homogeneity of the material, a leakage current problem or a mounting issue. Further detectors will be tested over the next few months to determine the root cause. However, 3 or 6 detectors fabricated to date exhibit acceptable performance.

The performance of any pixel, with the analog output routed directly to a high quality ADC, will always be superior than that from a system designed for counting. The imager has the capability to generate 256 channel spectra, by sweeping a narrow window through the energy range. This allows the unit to generate spectra from all pixels without the use of an external MCA. Figure 5 shows the outputs from 1 ASIC on the test unit. It can be seen that the spectra exhibit the same form as spectra obtained with the MCA, but the value of the FWHM is higher. This can be attributed to the much-reduced precision of the analog-digital conversion in this case. However, it is clear that this system can be used to locate the peak position, calculate the energy resolution and photo peak efficiency and hence calibrate the system across all pixels.

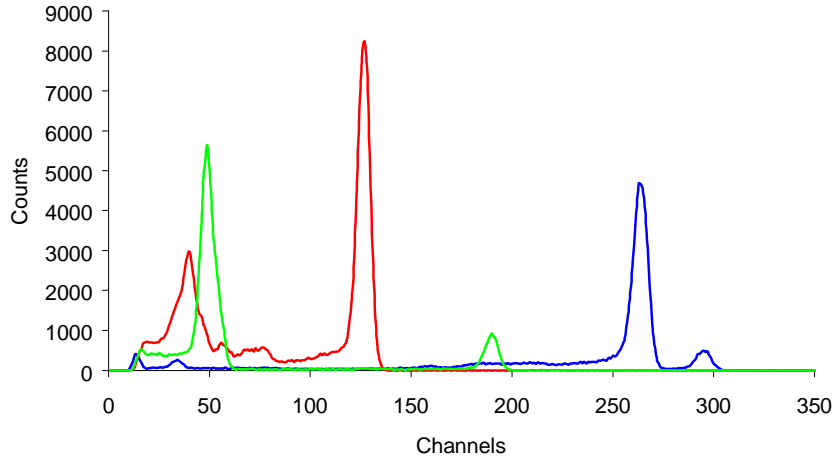

Figure3: Low energy response of a randomly chosen pixel

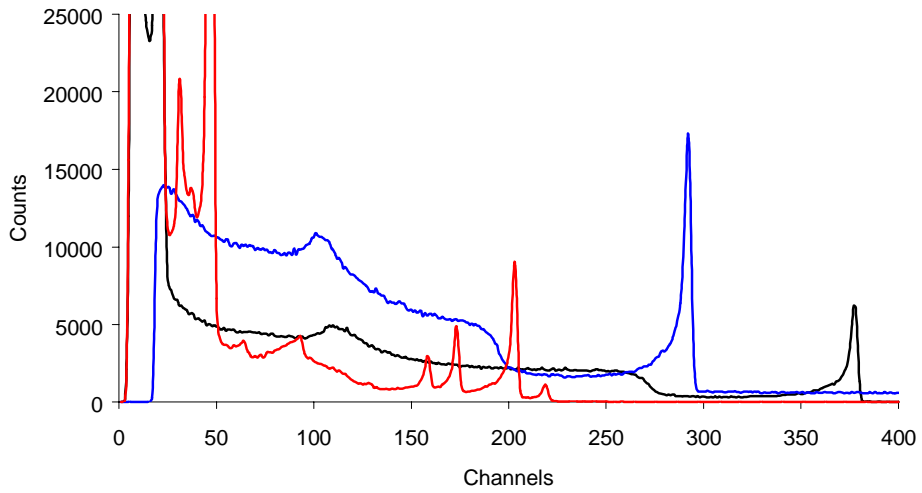

Figure 4: High energy response of the same pixel

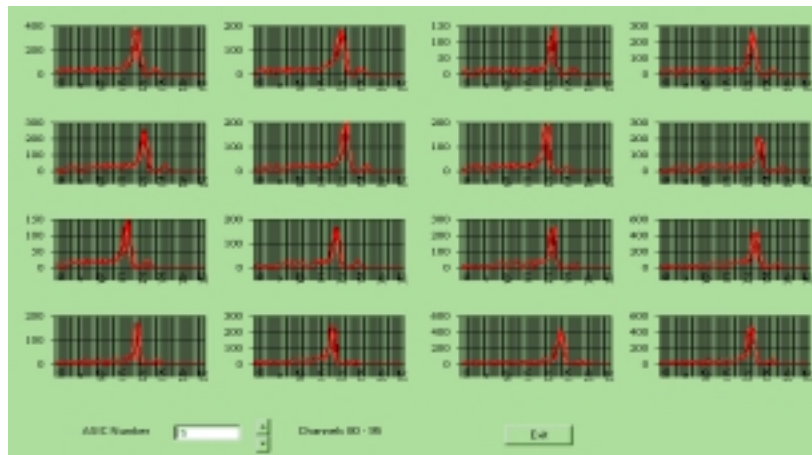

Figure 5: Output from 1 ASIC, demonstrating the performance of a CdZnTe detector. Average energy resolution is 3.6% +/- 0.4%

The above results are all taken in the laboratory and indicate the best performance the imager can demonstrate. However, a very preliminary comparative evaluation of the eV PRODUCTS CdZnTe imager was performed using a 5cm compressed breast phantom with centrally placed 6mm spherical "lesion". An uptake ratio of 7.5:1 (lesion to "breast tissue") of Tc-99m was simulated. The radioactivity levels in the "breast" and in the "lesion" were equivalent to an average patient breast uptake of 0.6 and 4.5  $\mu\text{Ci/cc}$ , respectively. The imaging time was set at a 5 minutes, which could be expected in a patient case. Three detectors were used in the study. The first was based on a 5x5 array of R7600-00-C8 Hamamatsu position sensitive PMTs and a pixellated array of 41x41 of NaI(Tl) scintillator pixels 3x3x6mm in size with a 3.3mm step, from Saint Gobain Crystals and Detectors. The active surface coverage of this detector is about 132mm square. The second scintillation detector had a high granularity NaI(Tl) array of 1x1x5mm pixels with a 1.25mm step (septa thickness in both cases was 0.25mm) coupled to a 3" square R2687 Hamamatsu position sensitive PMT. The active surface of this array was 58.25mm by 54.50mm. Both of these units were provided by Stan Majewski of Jefferson National Laboratory<sup>10,11</sup>. Finally, the third detector was the SFOV gamma camera prototype described above. The same type medium resolution collimator was used on all the detectors. Its resolution at the lesion distance of 3cm from the collimator surface was about 4.6mm FWHM, as measured with the 1.25mm pixel step detector.

The images and corresponding plots for the three detectors are shown below in figures 6-8. As can be seen from this very preliminary test, the CZT detector operated successfully and achieved similar high contrast as the high resolution NaI(Tl) detector. Based on its much better demonstrated energy resolution, it is anticipated that the CZT detector will allow for better scatter rejection, especially in the breast region close to the chest wall.

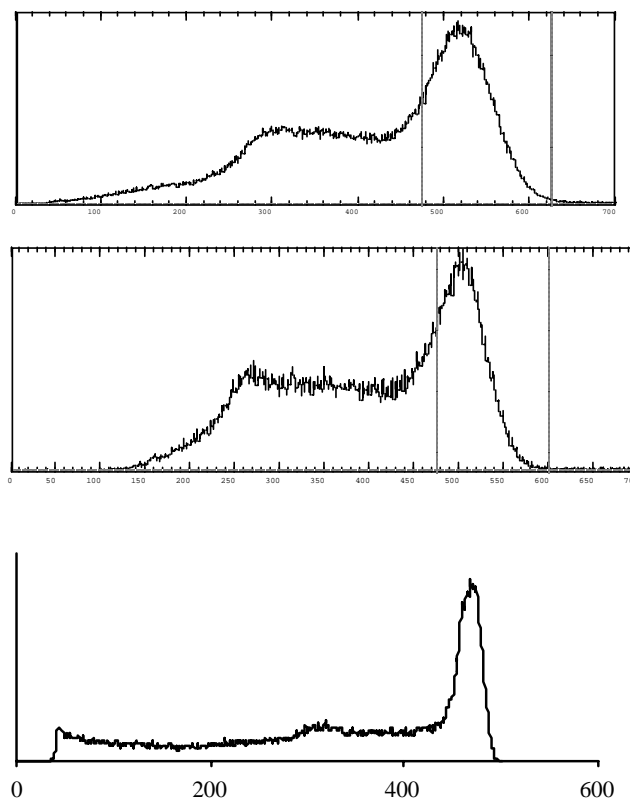

Figure 6: Single pixel energy spectra obtained in the 5 x 5 detector (top), 3" detector (middle) and the CZT detector (bottom) at 140 keV (Tc-99m) with the 4cm flat flood phantom. Higher discriminator thresholds were used in the scintillator detectors suppressing the low energy part of the pulse-height spectrum. Energy resolution of 19%, 17% and 7% FWHM at the photopeak energy was obtained, respectively.

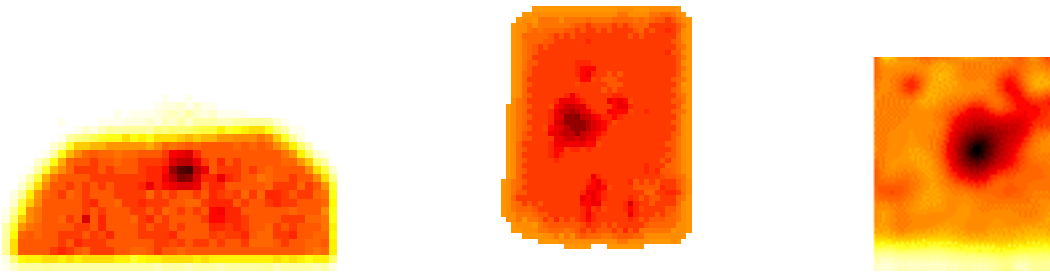

Figure 7: Images of the breast phantom with the 6mm lesion; from left to right: 5" x 5" PSPMT array detector, 3" PSPMT detector and CZT detector. Please note that orientation of the phantom in the images is different for different detectors.

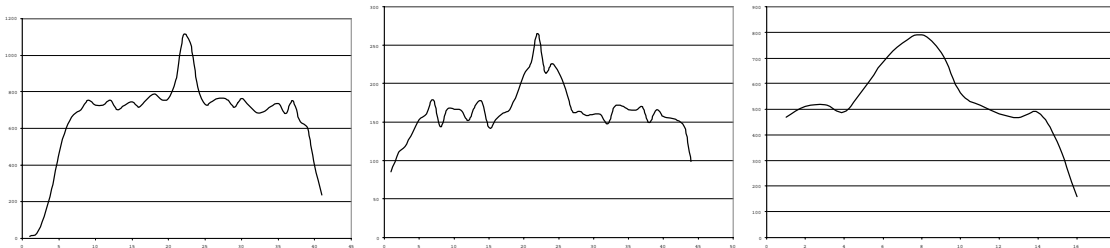

Figure 8: Profiles through the lesion for the three detector cases.

Contrast values of 48%, 58%, and 54% were obtained for the 5 x 5 PSPMT array detector, 3" PSPMT detector, and CZT detector, respectively. Please note different pixels sizes: 3.3mm, 1.25mm, and 2 mm, respectively.

#### 4. CONCLUSIONS

A Small Field of View (SFOV) gamma camera operating on a different principle than most existing gamma cameras has been designed, constructed and demonstrated. Energy resolution in the range of 3-4% @ 122 keV is possible on a routine basis, with >95% of the pixels operating in this regime. The system can be used from ~ 15 keV up to 511 keV, rendering it suitable for almost all commonly used radiotracers. Photopeak efficiencies of 70-80% are achievable at 122keV. An initial trial performed alongside existing SFOV cameras demonstrates that the new device offers contrast ratios at least equal to existing devices, although more work is needed to optimize the system.

Further measurements will be made with this new system over the next few months, both to finalize the development of the self-calibration routines and also to characterize various aspects of the performance. We have not yet evaluated the count rate capabilities of the device, nor the limits of the position resolution that may be obtained.

#### ACKNOWLEDGEMENTS

We would like to express our thanks to all the personnel at eV PRODUCTS who helped make the fabrication of this device a possibility. We would also like to thank Dr. Stan Majewski and Dr. Cynthia Keppel of the Thomas Jefferson National Laboratory for their help in conducting the breast phantom tests.

#### REFERENCES

1. J. Wear *et al*, "CZT detector for dual energy x-ray absorptiometry (DEXA), presented at the 1999 SPIE Annual Meeting
2. M. Ricard, "Intraoperative detection of radiolabeled compounds using a hand-held gamma probe", *NIM A*, **458**, 26-33, 2001
3. J. F. Butler *et al*, *IEE Trans. Nucl., Sci.*, **NS-45**, 359, 2001

4. Y. Eisen *et al*, *NIM A*, **380**, 474, 1996
5. C. Mestais *et al*, "A new design for a high resolution, high efficiency CZT gamma camera", *NIM A*, **458**, 62-67, 2001
6. G. A. Kastis *et al*, "Tomographic small animal imaging using a high-resolution semi-conductor camera", *IEEE/NSS Symposium Conference record*, 21-31, 2000
7. C. Scheiber *et al*, "Medical Applications of CdTe and CdZnTe detectors", *NIM A*, **458**, 12-25, 2001
8. K. Iwata *et al*, Design of combined x-ray CT and SPECT systems for small animals", *IEEE/NSS Symposium Conference record*, 1999
9. G. De Geronimo *et al*, "A generation of CMOS readout ASIC's for CZT detectors" *IEEE/NSS Symposium Conference record*, 1999
10. A.G. Weisenberger *et al*, "A Combined Scintimammography / Stereotactic Core Biopsy Digital X-ray System", presented at the IEEE Nuclear Science Symposium and Medical Imaging Conference, Lyon, France; October 15-20, 2000.
11. S. Majewski *et al*, "Optimization of Dedicated Scintimammography Procedure Using Detector Prototypes and Compressible Phantoms", presented at the IEEE Nuclear Science Symposium and Medical Imaging Conference, Lyon, France; October 15-20, 2000, to be published in the IEEE Transactions on Nuclear Science, 2001, and references therein.